

1 PRODUCT OVERVIEW

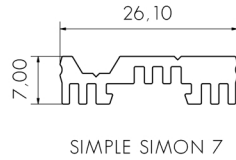

2 INSTALL EXTRUSION & LED STRIP

1. DRILL 4MM HOLES IN EXTRUSION'S SCREW CHANNEL AT APPROXIMATELY 400MM CENTRES. IF USING HIGH-WATTAGE STRIPS OR IF PRODUCT IS USED IN A CONFINED SPACE, CREATE SLOTTED HOLES TO ALLOW EXTRUSION TO EXPAND AND CONTRACT. 8MM LONG SLOTS WILL SUIT MOST APPLICATIONS.

2. DRILL 6MM HOLE FOR LOW VOLTAGE POWER FEED AT ONE END, OR AS REQUIRED BASED ON LED STRIP MANUFACTURER'S RECOMMENDATIONS.

3. IF USING MULTIPLE LENGTHS OF EXTRUSION, JOIN USING JOINER AND LOCK TOGETHER WITH GRUB SCREWS.

4. FEED LOW VOLTAGE CABLE FROM DRIVER THROUGH CABLE ENTRY HOLE IN EXTRUSION.

5. MAKE ELECTRICAL CONNECTION: CONNECT LED STRIP TAILS TO LED DRIVER CABLE, THEN SEAL WITH HEAT SHRINK.

6. SCREW-FIX EXTRUSIONS TO SURFACE USING 3.5X30 CSK SELF-TAPPING OR WOOD SCREWS (SEE FIG. 1).

7. **IMPORTANT:** BEFORE MOUNTING LED STRIP, CLEAN EXTRUSION USING AN ALCOHOL BASED CLEANER.

8. REMOVE BACKING FROM LED STRIP TO EXPOSE STICKY SURFACE. LAY LED STRIP INTO EXTRUSION. USE A DAB OF SILICON AT EACH END OF THE LED STRIP TO PREVENT ENDS FROM LIFTING OFF EXTRUSION.

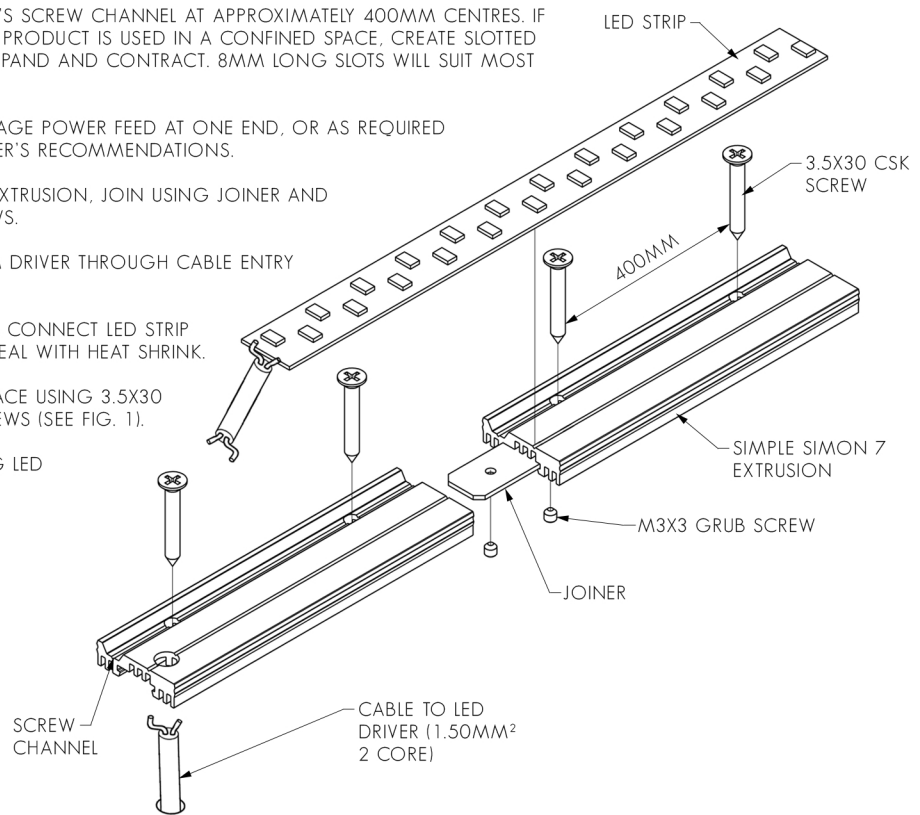

FIG. 1 - ENSURE EXTRUSION IS MOUNTED SECURELY

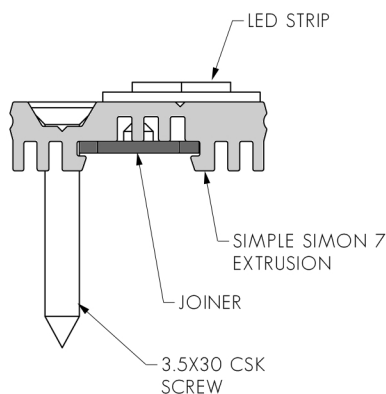

FIG. 2 - COMPLETE INSTALLATION

