

1

PRODUCT OVERVIEW

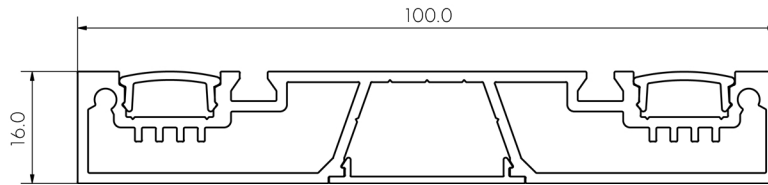

SWEET 16

2

DRILL HOLES FOR SUSPENSION CEILING ATTACHMENTS AND INSTALL

NOTE: SUSPENSIONS MUST BE WITHIN 200MM OF EACH END AND WITHIN 200MM EITHER SIDE OF A JOIN OR BEND. E.G. A 2500MM EXTRUSION SHOULD HAVE 3 MOUNTING POINTS, ONE CENTRED AND ONE EACH END WITHIN 200MM.

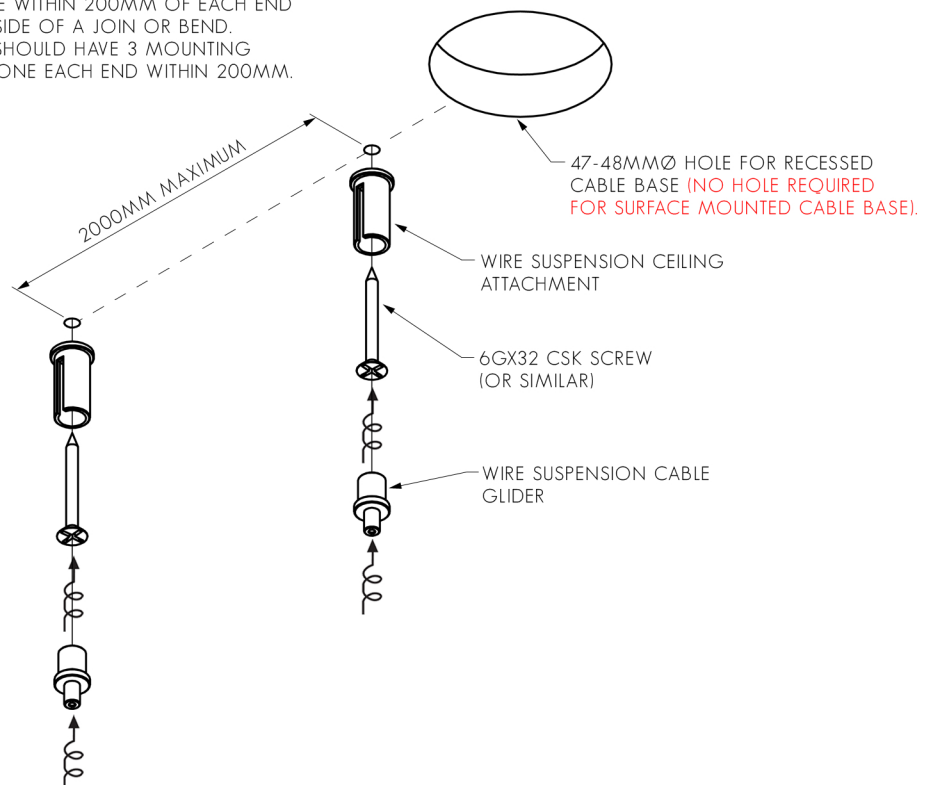

3

INSTALL SUSPENSION CABLES, HANG EXTRUSION, JOIN EXTRUSIONS

1. SLIDE WIRE SUSPENSIONS INTO EXTRUSION AS SHOWN (SEE FIG. 1).
2. FEED WIRE SUSPENSION CABLES IN TO CEILING ATTACHMENTS. PRESS NIPPLE INWARDS TO ADJUST CABLE LENGTH (SEE FIG. 2).
3. IF USING MULTIPLE LENGTHS OF EXTRUSION, SLIDE EXTRUSIONS TOGETHER ON TO JOINER OR BEND PLATE (SEE FIG. 3).
4. ONCE CORRECT SUSPENSION HEIGHT HAS BEEN SET, CUT OFF EXCESS SUSPENSION WIRE USING SIDE CUTTERS. (SEE FIG. 2).

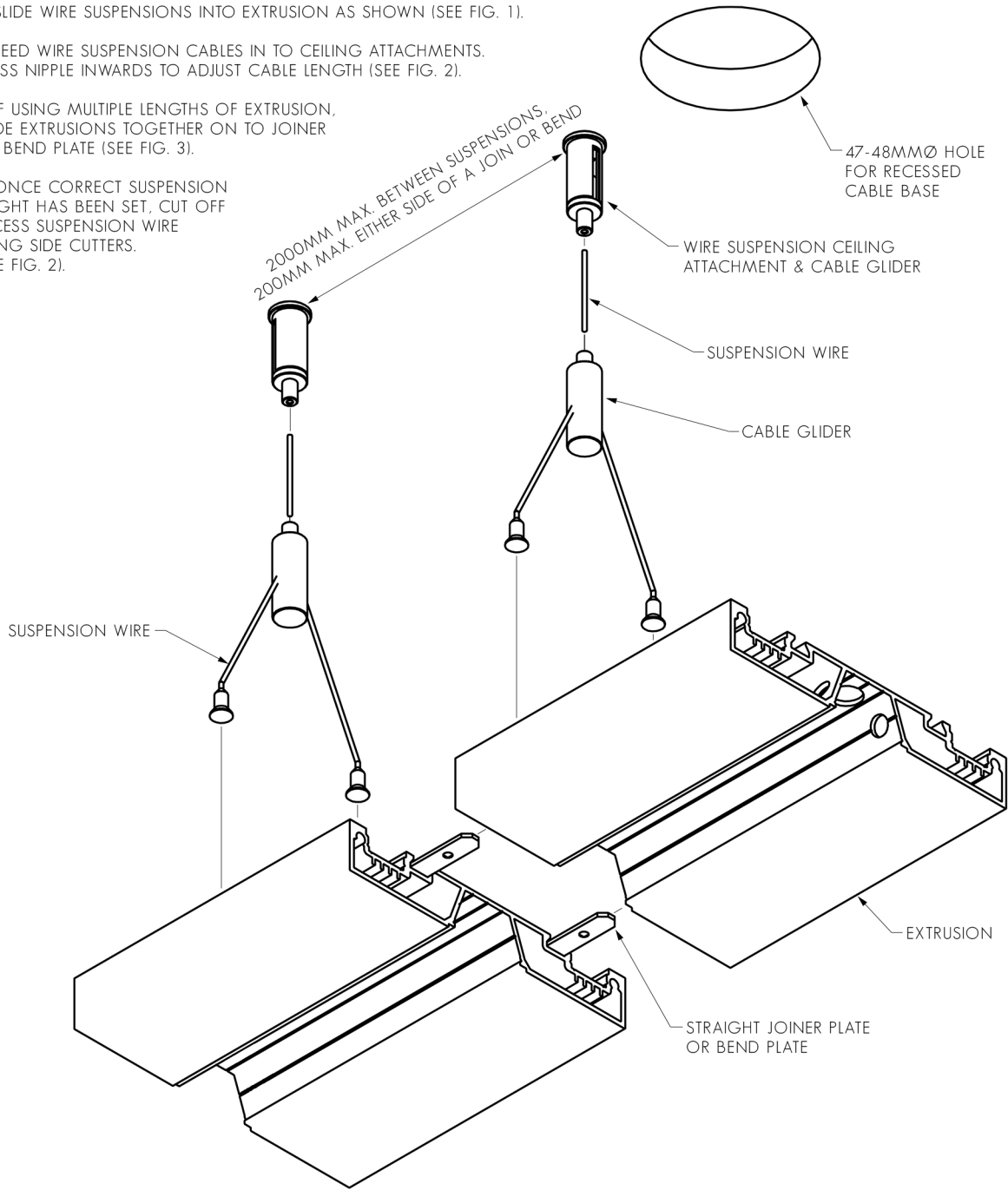

FIG. 1 - ENSURE SUSPENSION WIRES ARE MOUNTED SECURELY

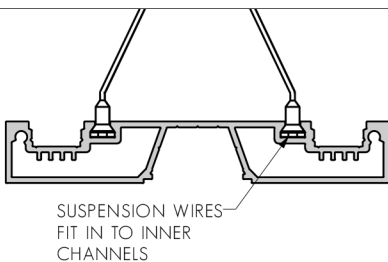

FIG. 2 - ADJUST SUSPENSION CABLE

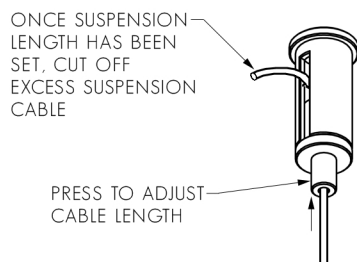
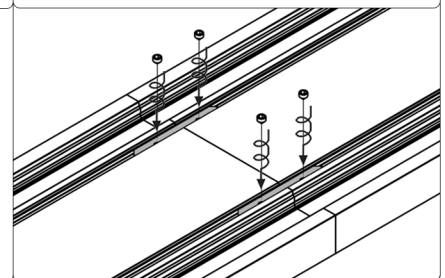

FIG. 3 - TIGHTEN SCREWS IN JOINER/BEND PLATES



4 MAKE ELECTRICAL CONNECTION, INSTALL CABLE BASE, CLEAN EXTRUSION, INSTALL LED STRIP, DIFFUSER AND END CAPS

1. FEED LED STRIP TAILS (OR CABLE) THROUGH HOLE IN EXTRUSION AND CLAMP USING CORD GRIP SUPPLIED (SEE FIG. 4). DO NOT INSTALL LED STRIP AT THIS POINT.
2. MAKE ELECTRICAL CONNECTION: CONNECT LED STRIP TAILS TO LED DRIVER USING CRIMP CONNECTORS, THEN SEAL WITH HEAT SHRINK.
3. PUSH CABLE BASE INTO HOLE IN CEILING - SEE FIG. 5 OR FIG. 6 FOR SURFACE MOUNTED CABLE BASE.
4. **IMPORTANT:** BEFORE MOUNTING LED STRIP, CLEAN EXTRUSION USING AN ALCOHOL BASED CLEANER.
5. REMOVE BACKING FROM LED STRIP TO EXPOSE STICKY SURFACE. LAY LED STRIP INTO EXTRUSION, USING THE SMALL GROOVES IN THE BACK OF THE EXTRUSION AS A GUIDE.
6. CLIP DIFFUSER INTO EXTRUSION, ENSURING A FIRM CONNECTION (SEE FIG. 7).
7. SLIDE END CAPS INTO ENDS OF EXTRUSION.

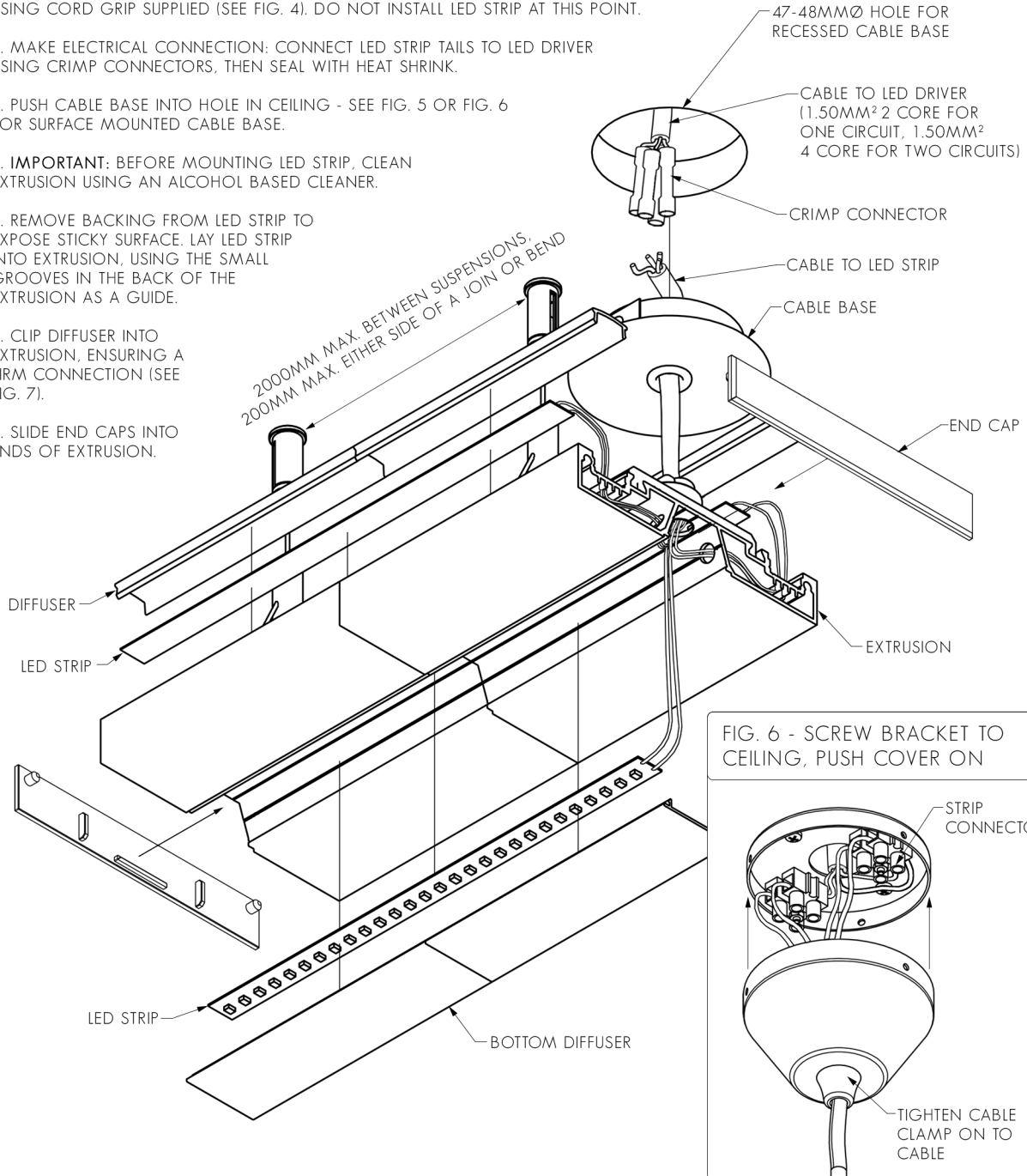

FIG. 6 - SCREW BRACKET TO CEILING, PUSH COVER ON

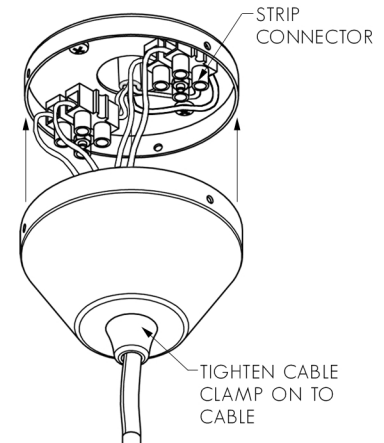

FIG. 4 - FASTEN CABLE USING CORD GRIP

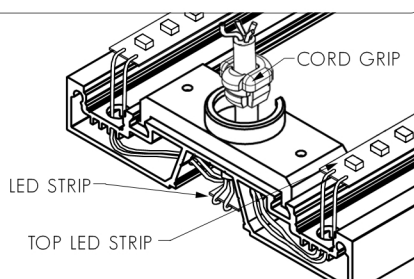

FIG. 5 - INSERT CABLE BASE IN TO CEILING

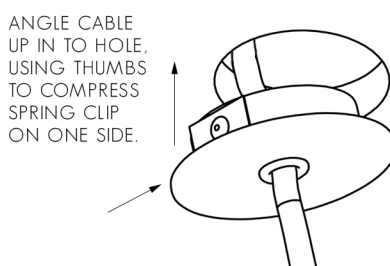

FIG. 7 - ENSURE DIFFUSER IS MOUNTED SECURELY

