

1 PRODUCT OVERVIEW

DOWNHILL DAN 30

FLAT FREDDIE 30

2 FIX WALL BRACKETS IN TO A SOLID FIXING

WALL BRACKET

CABLE TO LED DRIVER (1.50MM² 2 CORE)

MOUNTING CLIP

6GX32 CSK SCREW (OR SIMILAR)

M3 FLAT WASHER

M3X4 PAN HEAD SCREW

MAXIMUM DISTANCE BETWEEN WALL BRACKETS IS 800MM AND NO FURTHER THAN 200MM IN FROM AN END OR JOIN.

3 JOIN EXTRUSIONS, INSTALL END CAPS AND CLIP EXTRUSION TO WALL BRACKETS

WALL BRACKET & MOUNTING CLIP

EXTRUSION

CABLE TO LED DRIVER

CABLE TO LED STRIP

M3X3 GRUB SCREW

JOINER PLATE

END CAP

1. IF USING MULTIPLE LENGTHS OF EXTRUSION, SLIDE EXTRUSIONS TOGETHER ON TO JOINER OR BEND PLATE AND TIGHTEN GRUB SCREWS.
2. SLIDE END CAPS INTO ENDS OF EXTRUSION.
3. CLIP EXTRUSIONS ON TO WALL BRACKETS. ENSURE EXTRUSION IS MOUNTED SECURELY. SEE FIG. 1.

THE CABLE FROM THE WALL SHOULD WRAP AROUND BEHIND THE MOUNTING CLIP AND ENTER THE EXTRUSION ALONGSIDE THE WALL BRACKET & CLIP.

FIG. 1 - ENSURE EXTRUSION IS MOUNTED SECURELY

"CLICK"

"CLICK"

CABLE TO LED DRIVER

4 INSTALL LED STRIP, MAKE ELECTRICAL CONNECTION

1. MAKE ELECTRICAL CONNECTION: CONNECT LED STRIP TAILS TO LED DRIVER. (SEE FIG. 2 IF SUPPLIED WITH MALE/FEMALE CONNECTORS).
2. IMPORTANT: BEFORE MOUNTING LED STRIP, CLEAN EXTRUSION USING AN ALCOHOL BASED CLEANER.
3. REMOVE BACKING FROM LED STRIP TO EXPOSE STICKY SURFACE. LAY LED STRIP INTO EXTRUSION, USING THE SMALL GROOVES IN THE BACK OF THE EXTRUSION AS A GUIDE.
4. CLIP DIFFUSER INTO EXTRUSION, ENSURING A FIRM CONNECTION (SEE FIG. 3).

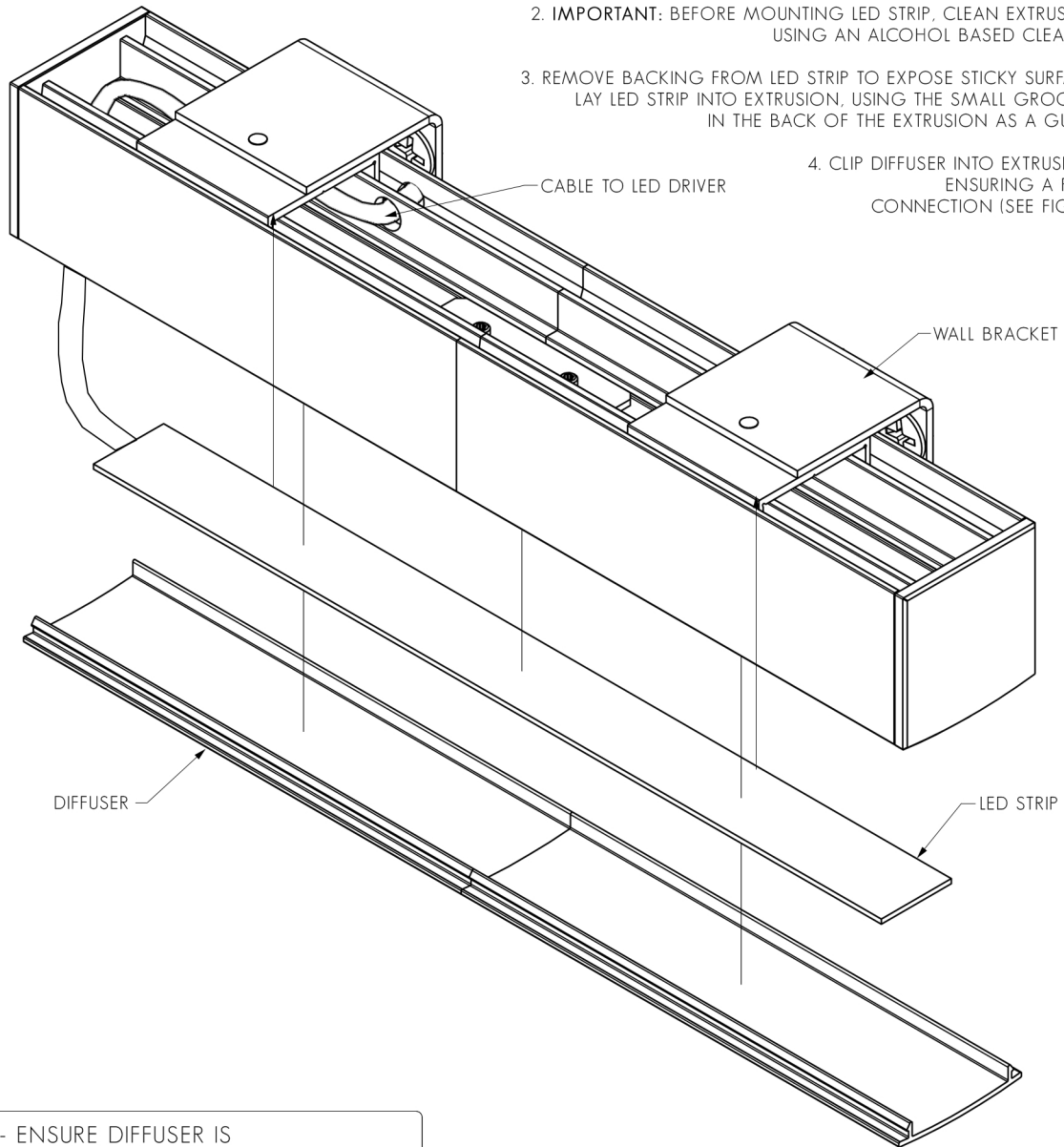

FIG. 3 - ENSURE DIFFUSER IS MOUNTED SECURELY

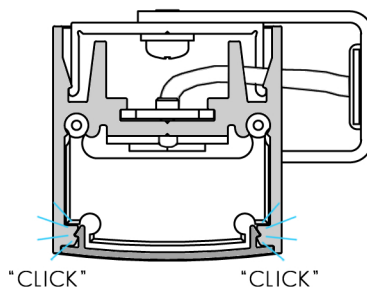

FIG. 2 - MAKE ELECTRICAL CONNECTION

