

1 PRODUCT OVERVIEW

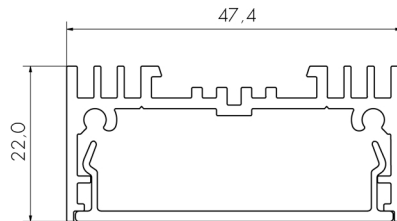

2 MOUNT EXTRUSION, MAKE ELECTRICAL CONNECTION.

1. FEED LED STRIP TAILS (OR CABLE) THROUGH HOLE IN EXTRUSION AND CLAMP USING CORD GRIP SUPPLIED. (SEE FIG. 1). DO NOT INSTALL LED STRIP AT THIS POINT.
2. MAKE ELECTRICAL CONNECTION: CONNECT LED STRIP TAILS TO LED DRIVER (SEE FIG. 2 IF SUPPLIED WITH MALE/FEMALE CONNECTORS).
3. INSERT END CAPS IN TO EXTRUSION.
4. IF USING MULTIPLE LENGTHS OF EXTRUSION, SLIDE EXTRUSIONS TOGETHER ON TO JOINER OR BEND PLATE.
5. SCREW EXTRUSION TO SURFACE.

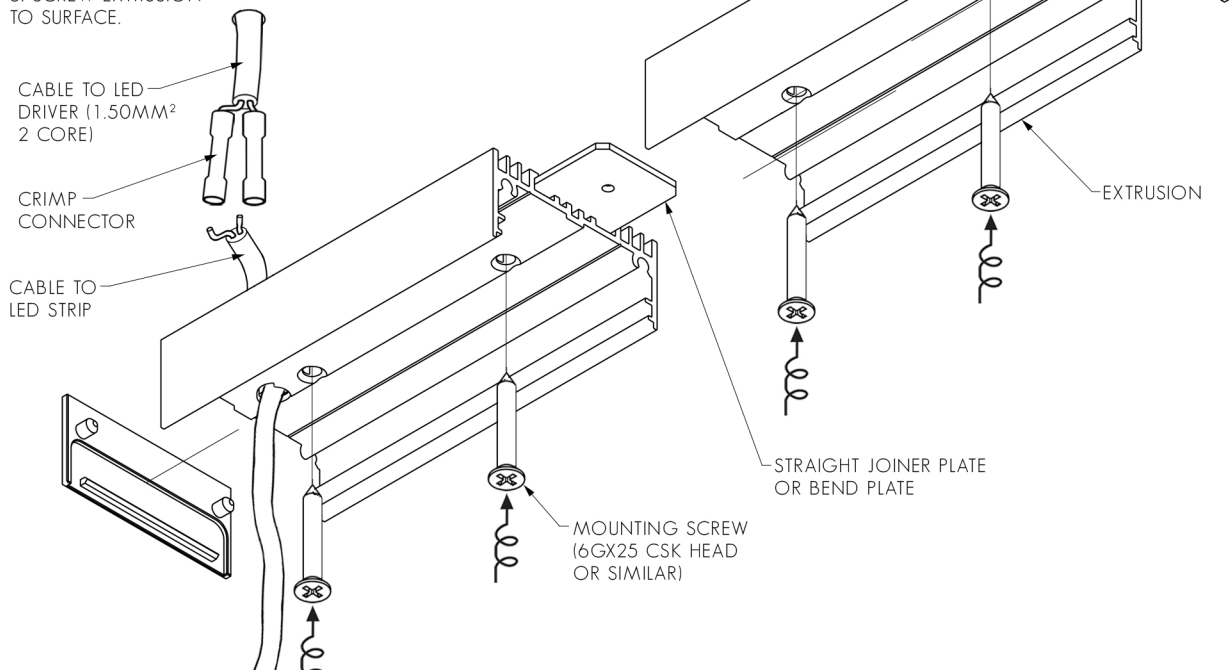

FIG. 1 - FASTEN CABLE USING CORD GRIP

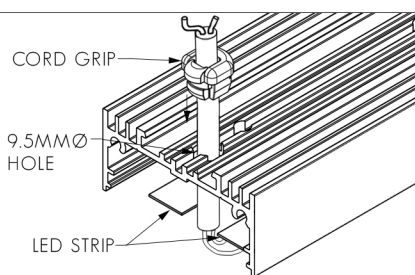

FIG. 2 - MAKE ELECTRICAL CONNECTION

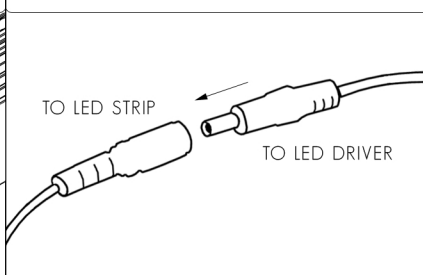
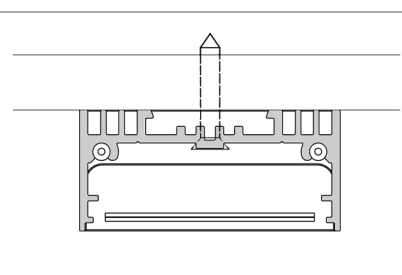

FIG. 3 - ENSURE EXTRUSION IS MOUNTED SECURELY



**3** CLEAN EXTRUSION, INSTALL LED STRIP AND DIFFUSER.

1. **IMPORTANT:** BEFORE MOUNTING LED STRIP, CLEAN EXTRUSION USING AN ALCOHOL BASED CLEANER.

2. REMOVE BACKING FROM LED STRIP TO EXPOSE STICKY SURFACE. LAY LED STRIP INTO EXTRUSION. LED STRIPS SHOULD SIT SNUGLY AGAINST RIDGE IN CENTRE OF EXTRUSION. SEE FIG. 4 FOR PLACEMENT. USE A DAB OF SILICON AT EACH END OF THE LED STRIP TO PREVENT ENDS FROM LIFTING OFF EXTRUSION.

3. CLIP DIFFUSER INTO EXTRUSION, ENSURING A FIRM CONNECTION (SEE FIG. 4).

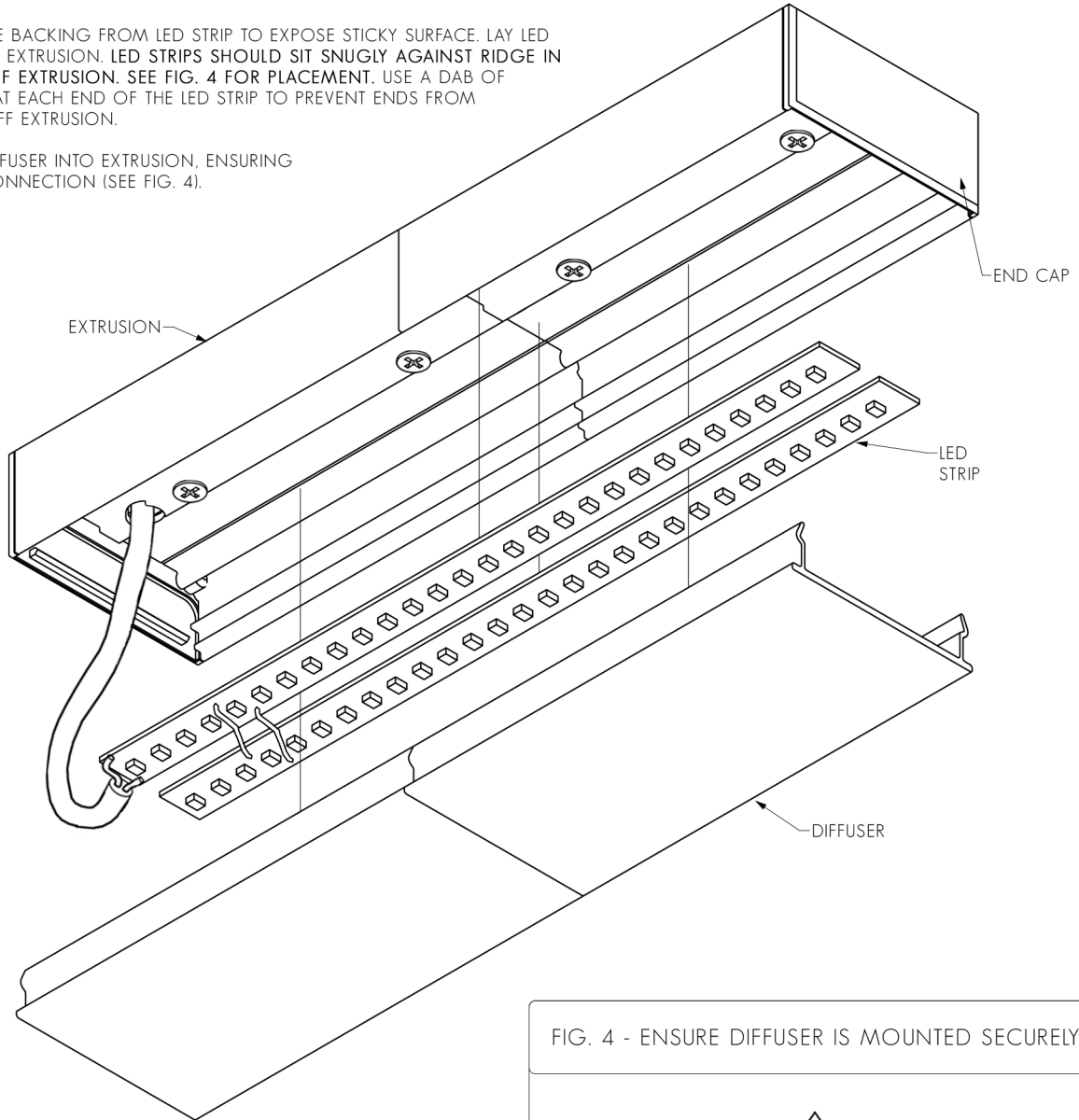

FIG. 4 - ENSURE DIFFUSER IS MOUNTED SECURELY

