

1 PRODUCT OVERVIEW

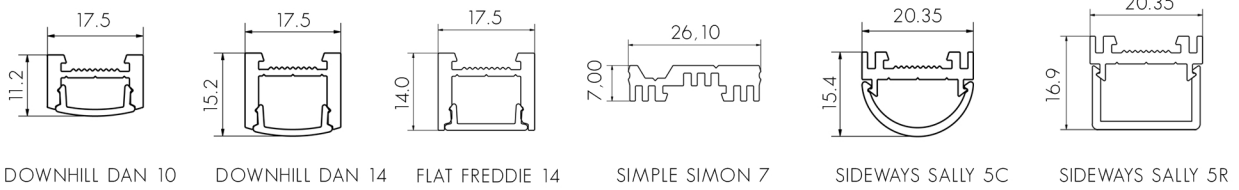

2 INSTALL EXTRUSION & LED STRIP

1. DRILL 6MM HOLE FOR LOW VOLTAGE POWER FEED AT ONE END, OR AS REQUIRED BASED ON LED STRIP MANUFACTURER'S RECOMMENDATIONS.
2. SLIDE ADJUSTABLE MOUNTING BRACKETS INTO EXTRUSION (SEE FIG. 1) AND LOCK IN PLACE USING GRUB SCREWS PROVIDED. BRACKETS SHOULD BE NO FURTHER THAN 850MM APART AND NO FURTHER THAN 300MM FROM AN END OR A JOIN.
3. IF USING MULTIPLE LENGTHS OF EXTRUSION, JOIN USING JOINER AND LOCK TOGETHER WITH GRUB SCREWS.
4. FEED LOW VOLTAGE CABLE FROM DRIVER THROUGH CABLE ENTRY HOLE IN EXTRUSION.
5. SCREW-FIX MOUNTING BRACKETS TO SURFACE USING 4.2X25MM PAN HEAD SCREW. IF REQUIRED, ROTATE SIMPLE SIMON 7 EXTRUSION ON BRACKETS FOR BETTER ACCESS TO SCREW HEADS.
6. MAKE ELECTRICAL CONNECTION: CONNECT LED STRIP TAILS TO LED DRIVER CABLE, THEN SEAL WITH HEAT SHRINK.
7. **IMPORTANT:** BEFORE MOUNTING LED STRIP, CLEAN EXTRUSION USING AN ALCOHOL BASED CLEANER.
8. REMOVE BACKING FROM LED STRIP TO EXPOSE STICKY SURFACE. LAY LED STRIP INTO EXTRUSION. USE A DAB OF SILICON AT EACH END OF THE LED STRIP TO PREVENT ENDS FROM LIFTING OFF EXTRUSION.

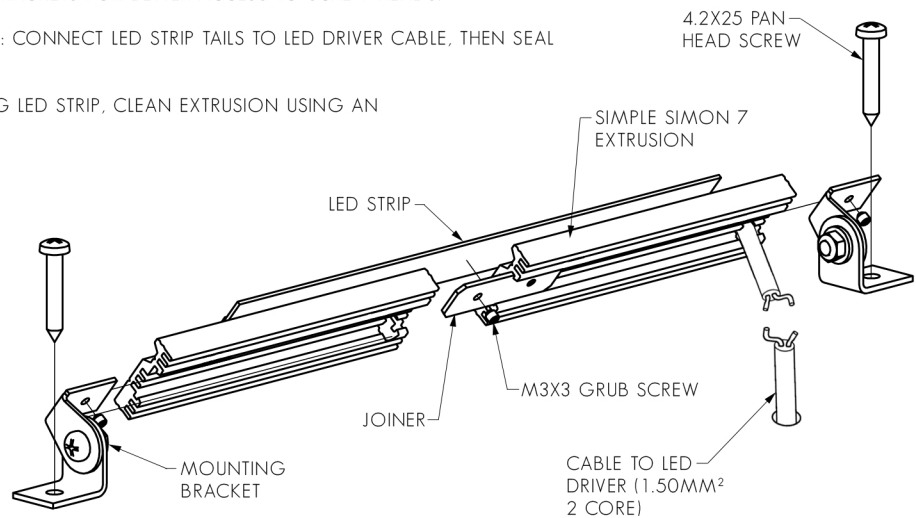

FIG. 1 - ENSURE EXTRUSION IS MOUNTED SECURELY. ROTATE IF REQUIRED.

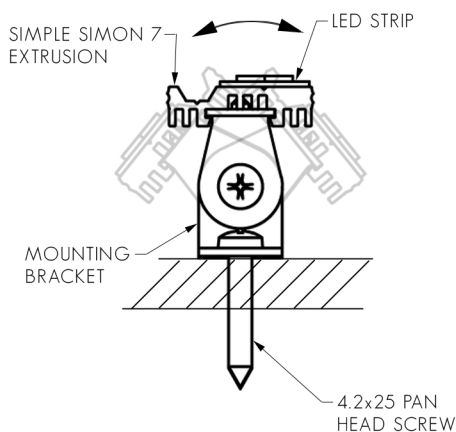

FIG. 2 - COMPLETE INSTALLATION

