

## 1

### PRODUCT OVERVIEW

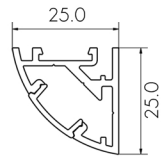

ANGLE ANDY 25

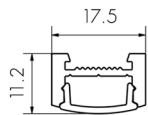

DOWNHILL DAN 10

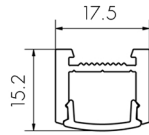

DOWNHILL DAN 14

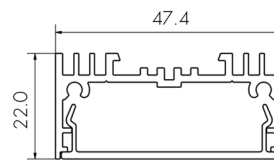

DOWNHILL DAN 22

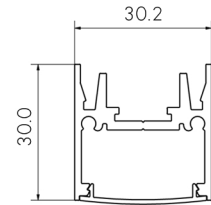

DOWNHILL DAN 30

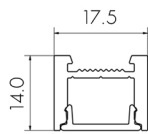

FLAT FREDDIE 14

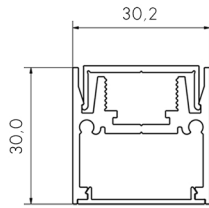

FLAT FREDDIE 30

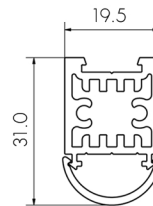

SIDEWAYS SALLY 20C

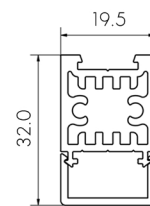

SIDEWAYS SALLY 20R

## 2

### JOIN EXTRUSIONS, ASSEMBLE ROD SUSPENSION

1. IF USING MULTIPLE LENGTHS OF EXTRUSION, SLIDE EXTRUSIONS TOGETHER ON TO JOINER OR BEND PLATE AND TIGHTEN GRUB SCREWS (SEE FIG. 1).
2. INSERT 'BASE' INTO TOP OF EXTRUSION AND ROTATE UNTIL IT STOPS.
3. INSERT 'CLAMP' OVER 'BASE' (THIS WILL STOP THE 'BASE' FROM ROTATING OUT OF EXTRUSION).
4. SCREW 'COLLAR' ON TO 'ROD SUSPENSION'.
5. SCREW 'ROD SUSPENSION' IN TO 'BASE' AND TIGHTEN (SEE FIG. 2).

FIG. 1 - TIGHTEN SCREWS IN JOINER/BEND PLATES

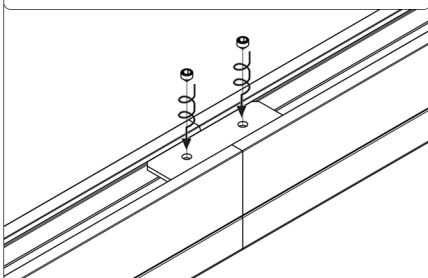
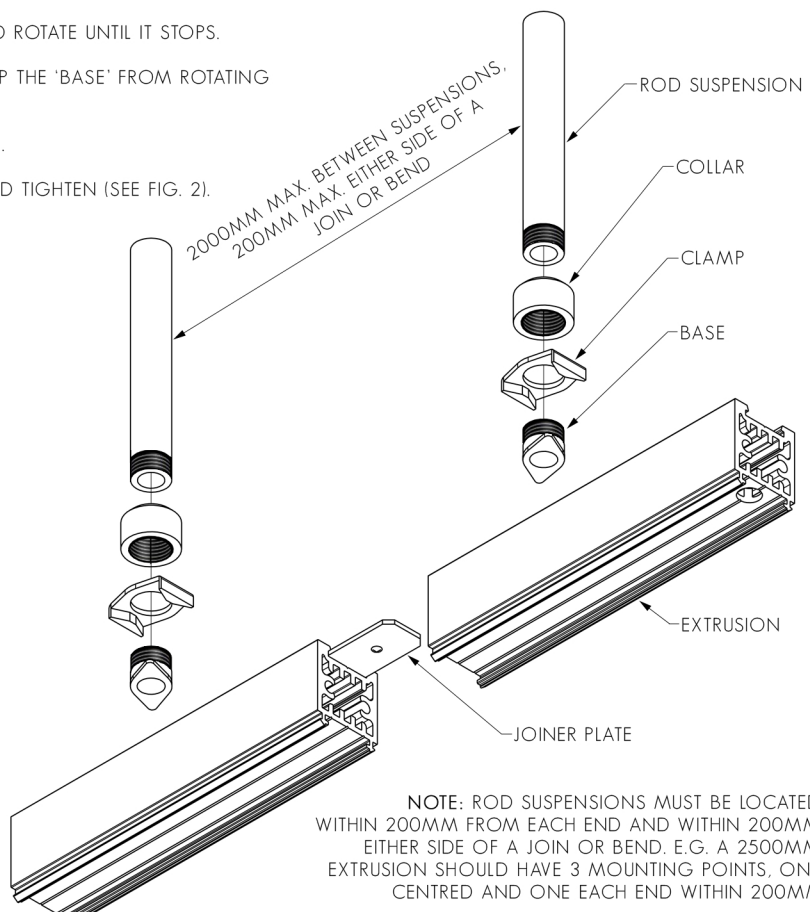
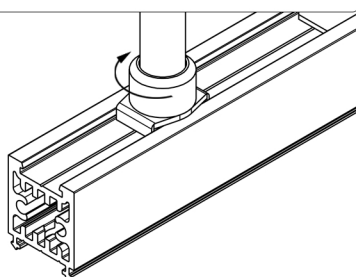

FIG. 2 - ENSURE EXTRUSION IS CLAMPED TIGHTLY



NOTE: ROD SUSPENSIONS MUST BE LOCATED WITHIN 200MM FROM EACH END AND WITHIN 200MM EITHER SIDE OF A JOIN OR BEND. E.G. A 2500MM EXTRUSION SHOULD HAVE 3 MOUNTING POINTS, ONE CENTRED AND ONE EACH END WITHIN 200MM.

3

FEED CABLE THROUGH ROD SUSPENSION, CLEAN EXTRUSION, INSTALL LED STRIP, DIFFUSER AND END CAPS

1. FEED LED STRIP TAILS (OR CABLE) THROUGH ROD SUSPENSION AND DOWN INTO EXTRUSION (SEE FIG. 3).
2. **IMPORTANT:** BEFORE MOUNTING LED STRIP, CLEAN EXTRUSION USING AN ALCOHOL BASED CLEANER.
3. REMOVE BACKING FROM LED STRIP TO EXPOSE STICKY SURFACE. LAY LED STRIP INTO EXTRUSION, USING THE SMALL GROOVES IN THE BACK OF THE EXTRUSION AS A GUIDE.
4. CLIP DIFFUSER INTO EXTRUSION, ENSURING A FIRM CONNECTION (SEE FIG. 4). FOR SIDWAYS SALLY 20, BE SURE NOT TO PUSH DIFFUSER IN TOO FAR. THERE SHOULD BE A SMALL GAP BETWEEN THE OUTSIDE FACE OF THE EXTRUSION AND THE DIFFUSER.
5. SLIDE END CAPS INTO ENDS OF EXTRUSION.

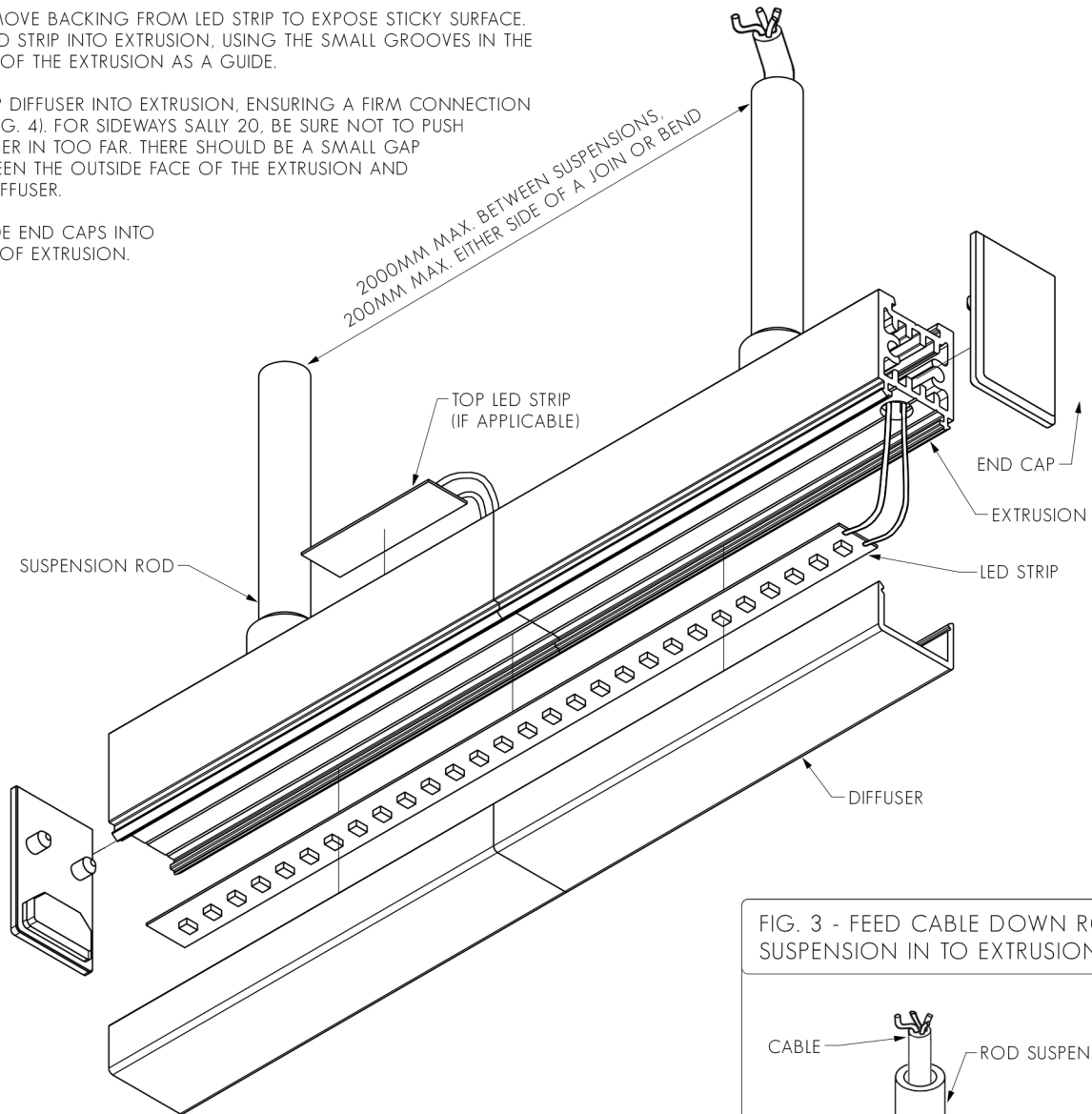

FIG. 3 - FEED CABLE DOWN ROD SUSPENSION IN TO EXTRUSION

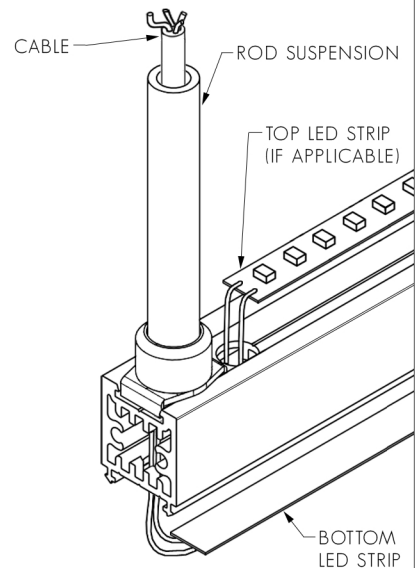
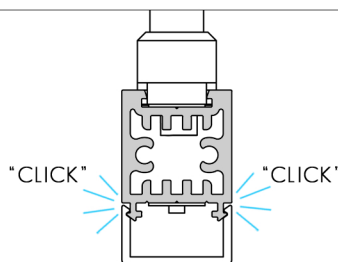

FIG. 4 - ENSURE DIFFUSER IS MOUNTED SECURELY



**4**

**ATTACH CEILING BRACKETS, HANG SUSPENSION RODS, MAKE ELECTRICAL CONNECTION, INSTALL CABLE BASE, CLEAN EXTRUSION, INSTALL LED STRIP, DIFFUSER AND END CAPS**

1. LIFT LIGHT ASSEMBLY UP TO CEILING AND MARK LOCATIONS OF RODS ON CEILING. USE MARKINGS TO CUT 47-48MMØ HOLES FOR CABLE BASES. SEE FIG. 4 FOR SURFACE MOUNTED CABLE BASE.

2. SCREW CEILING BRACKETS INTO FRAMING BEHIND PLASTERBOARD.

3. MAKE ELECTRICAL CONNECTION: CONNECT LED STRIP TAILS TO LED DRIVER USING CRIMP CONNECTORS, THEN SEAL WITH HEAT SHRINK.

4. LIFT LIGHT ASSEMBLY AND INSERT SUSPENSION RODS INTO CEILING BRACKETS, STARTING WITH THE POWER SUPPLY END. ADJUST REMAINING ROD SUSPENSION POSITIONS BY LOOSENING COLLARS AND REPOSITIONING. LOCK IN TO PLACE BY TIGHTENING GRUB SCREW ON ONE SIDE AND HEX HEAD SCREW ON OTHER SIDE, ENSURING HEX HEAD SCREW FITS THROUGH 4MMØ HOLE IN SUSPENSION ROD. (SEE FIG. 5)

5. PUSH CABLE BASE INTO HOLE IN CEILING (SEE FIG. 6).

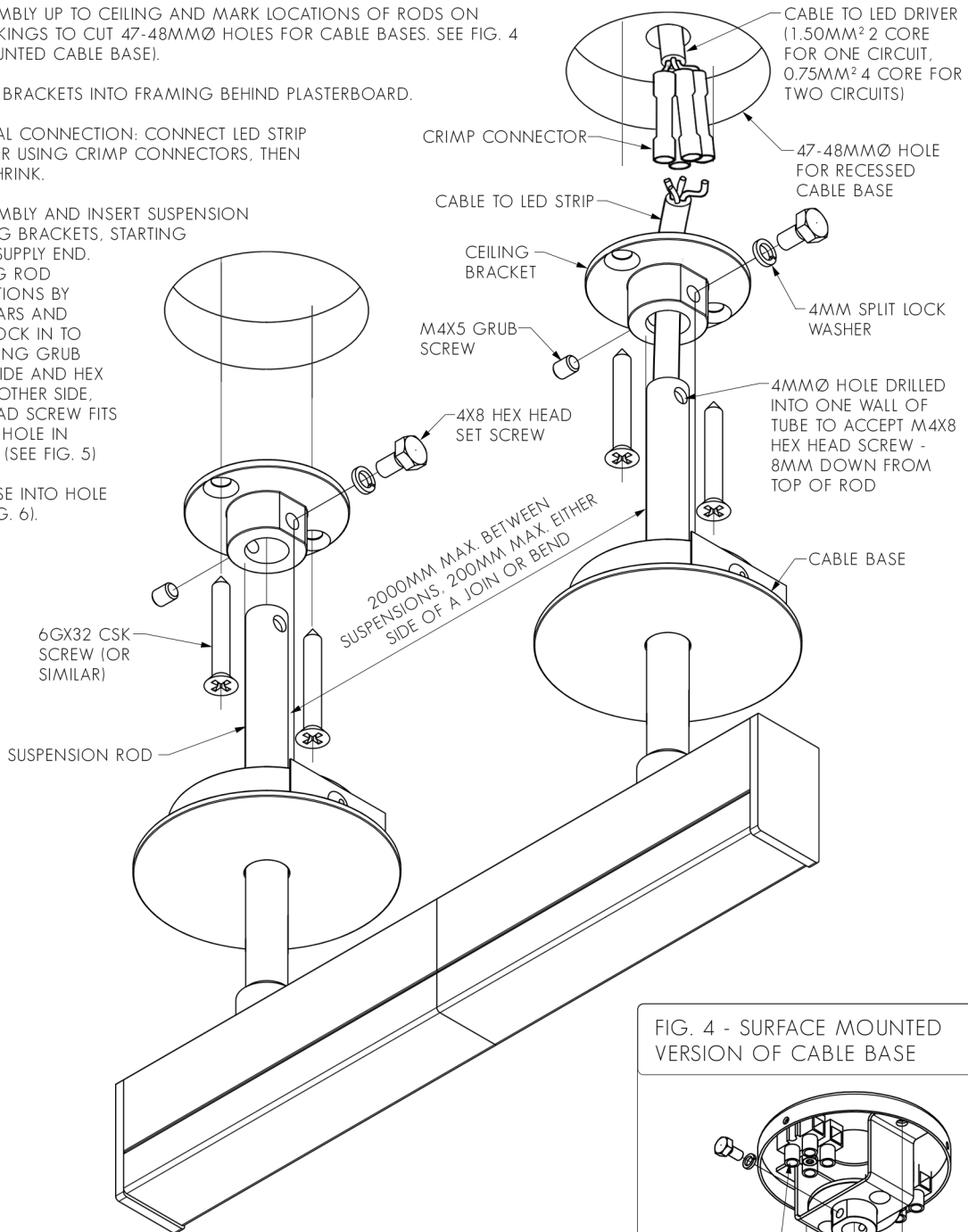

**FIG. 4 - SURFACE MOUNTED VERSION OF CABLE BASE**

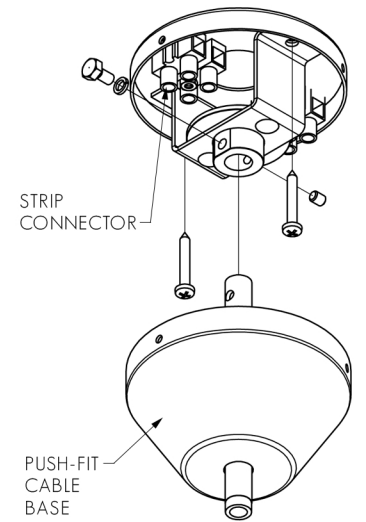

**FIG. 5 - ENSURE SUSPENSION RODS ARE TIGHTLY SECURED**

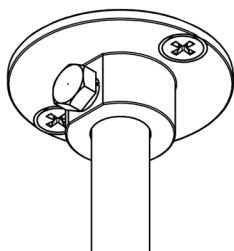

**FIG. 6 - INSERT CABLE BASE IN TO CEILING**

ANGLE CABLE UP IN TO HOLE, USING THUMBS TO COMPRESS SPRING CLIP ON ONE SIDE.

