

1 PRODUCT OVERVIEW

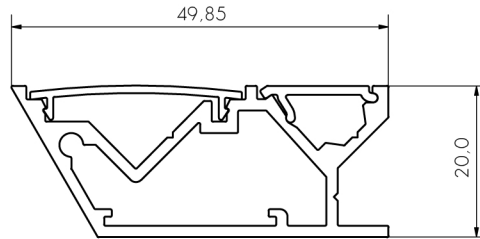

2 FIT END CAPS, MOUNT EXTRUSION

1. INSERT END CAPS IN TO EXTRUSION.
2. IF USING MULTIPLE LENGTHS OF EXTRUSION, SLIDE EXTRUSIONS TOGETHER ON TO JOINER OR BEND PLATE. USE A SHORT PIECE OF ELECTRICAL TAPE (OR SIMILAR) TO PREVENT JOINER FROM SLIDING TOO FAR INTO EXTRUSION. THE JOINER SHOULD SIT HALF WAY BETWEEN EACH EXTRUSION.
3. SCREW EXTRUSION/S TO WALL.
4. CLIP EXTRUSION LID OVER SCREW HEADS.

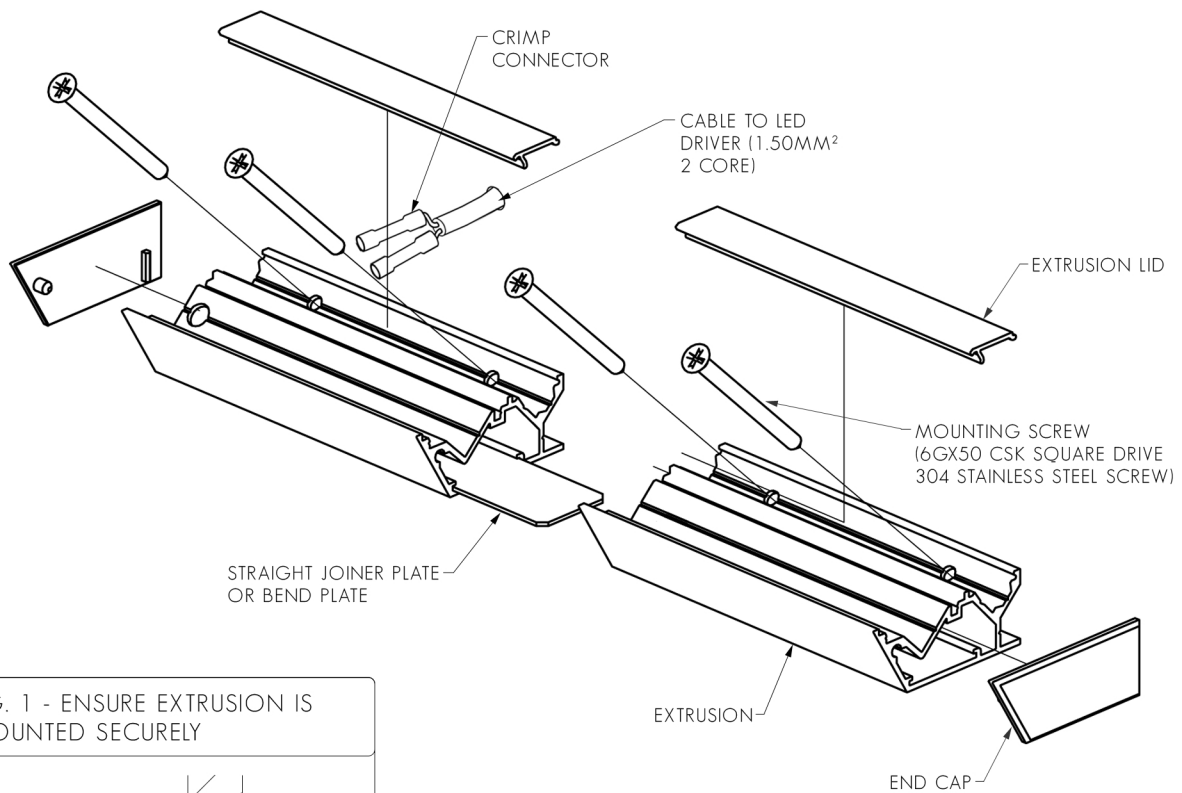
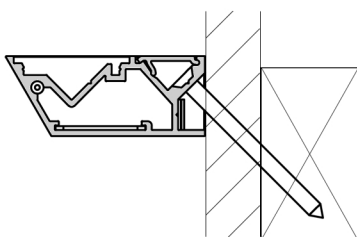

FIG. 1 - ENSURE EXTRUSION IS MOUNTED SECURELY



3 CLEAN EXTRUSION, INSTALL LED STRIP AND DIFFUSER.

1. **IMPORTANT:** BEFORE MOUNTING LED STRIP, CLEAN EXTRUSION USING AN ALCOHOL BASED CLEANER.
2. REMOVE BACKING FROM LED STRIP TO EXPOSE STICKY SURFACE. LAY LED STRIP INTO EXTRUSION. USE A DAB OF SILICON AT EACH END OF THE LED STRIP TO PREVENT ENDS FROM LIFTING OFF EXTRUSION.
3. CLIP DIFFUSER INTO EXTRUSION, ENSURING A FIRM CONNECTION (SEE FIG. 2).

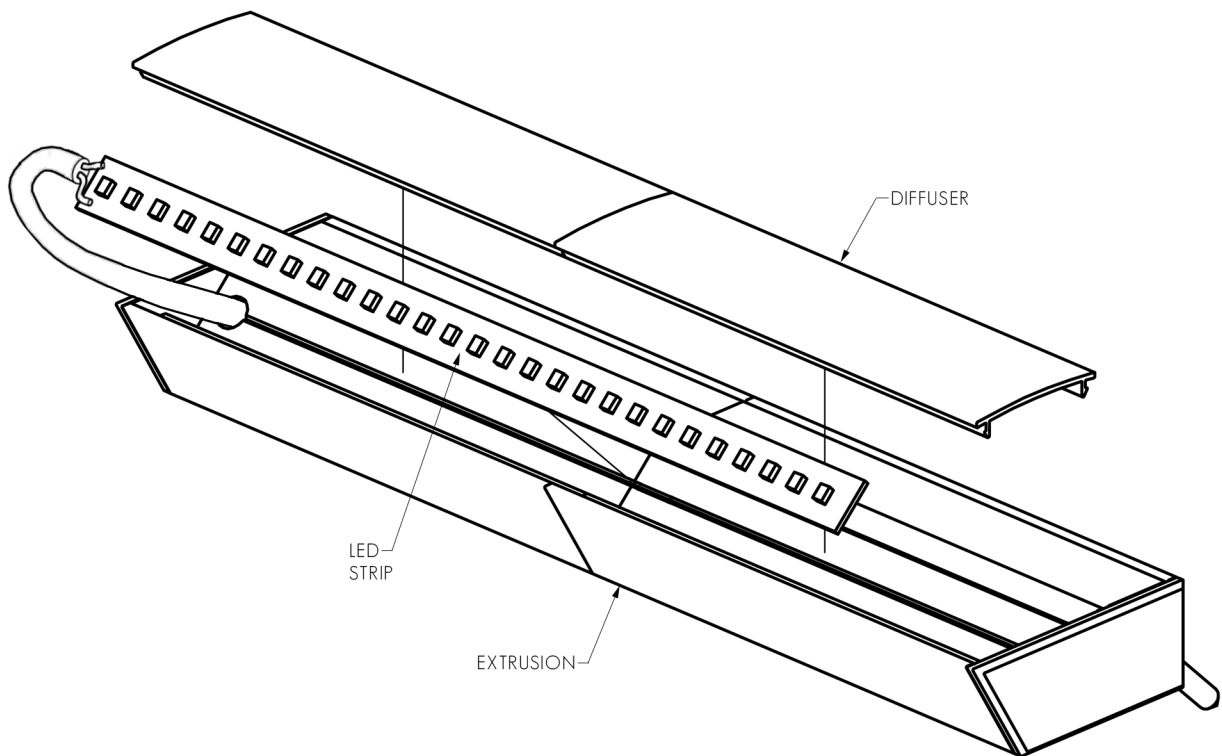

FIG. 2 - ENSURE DIFFUSER IS MOUNTED SECURELY

